



LO SERIES

LABEL ORIENTATION SYSTEMS uses an electronic eye and a motorized wheel to rotate products to a specific point. The orientation system rotates the product according to their label so that they are all facing in the same direction in the multipack, giving products their maximum shelf appeal. To facilitate the scanning of products, this system can rotate the product to position the UPC codes in a more accessible manner. In addition, the product orientation system can be used to rotate cans with handles, such as those found on paint cans.

POLYPACK'S LO SERIES are available as stand-alone units, or they can be installed on the infeed of a shrink-wraper, illustrating the effectiveness of our modular design.

- *Can be implemented on all Polypack equipment
- *Shelf ready multipacks with labels facing outward
- *Ideal for club store retail packaging
- *Available at speeds up to 60 packs/min.



WE GOT IT COVERED



DESIGNED TO ADAPT.
BUILT TO ENDURE.
POLYPACK.COM
727.578.5000

LO SERIES

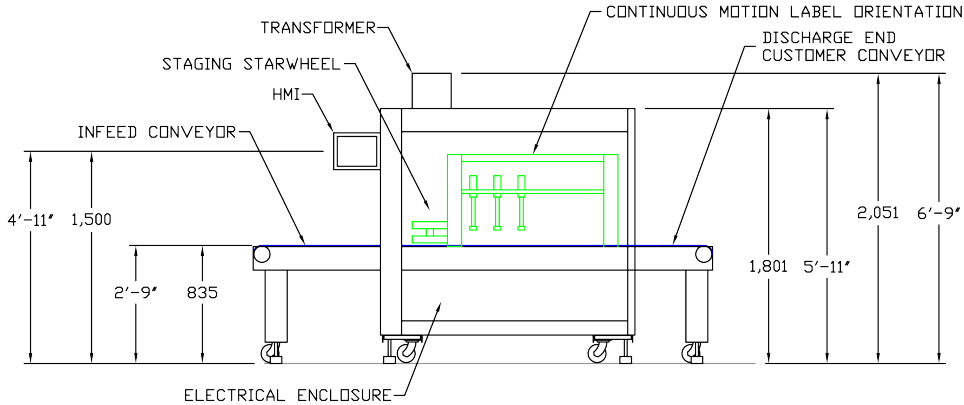
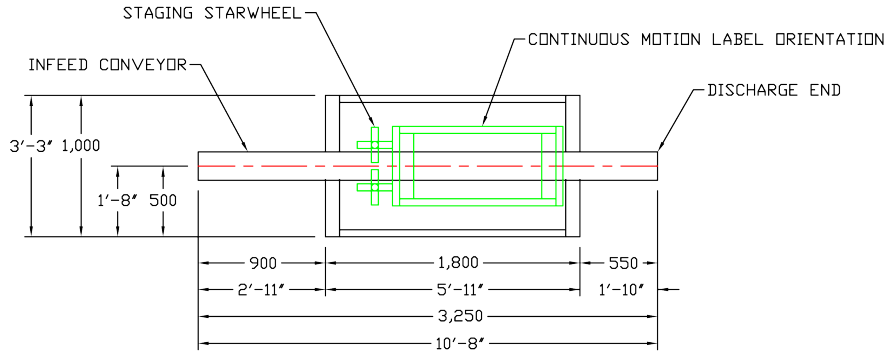

LABEL ORIENTATION SYSTEM FEATURES

- *Stainless Steel Main Frame
- *NEMA 12 Control Panel
- *208 - 575 volts - 3 phase, 50 or 60 hz.
- *Pneumatic controls require 65-70 p.s.i. (5 bars) @ 10 c.f.m.
- *Self-Monitoring Diagnostics

**WE GOT IT
COVERED**



CORPORATE HEADQUARTERS
3301 GATEWAY CENTRE BLVD.
PINELLAS PARK, FL 33782 USA

POLYPACK.COM
INFO@POLYPACK.COM
727.578.5000

