

## Turntable Stretch Wrapper

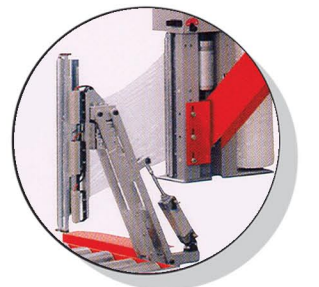

- **Patented, maintenance free stretch wrapper**  
*No installation costs, no chains or belts to maintain*
- **Ball bearing rotating table**  
*With external gear tooting for easy access*
- **Universal stretch film cut and clamp unit**  
*Automatically adjusting gripping, cutting and bonding*
- **Electronic pre-stretch film carriage**  
*Featuring a rapid film loading system*
- **Pallet anti-skid system**  
*Located on the turntable roller conveyor*
- **Touch screen control panel**  
*AB Micrologic programmable control panel and PanelView 600 Plus*
- **Motorized conveyor with rollers or chains**  
*Max. load size 51" x 43" x 86" high*
- **Top cover option available**  
*Reel located on the ground and inside safety zones*

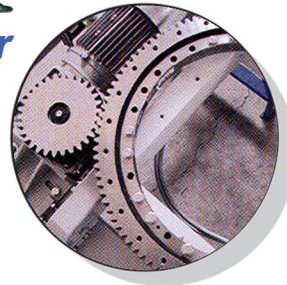

# MYTHO A

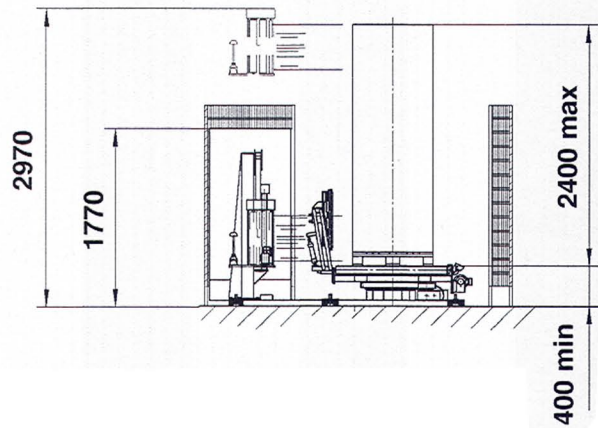
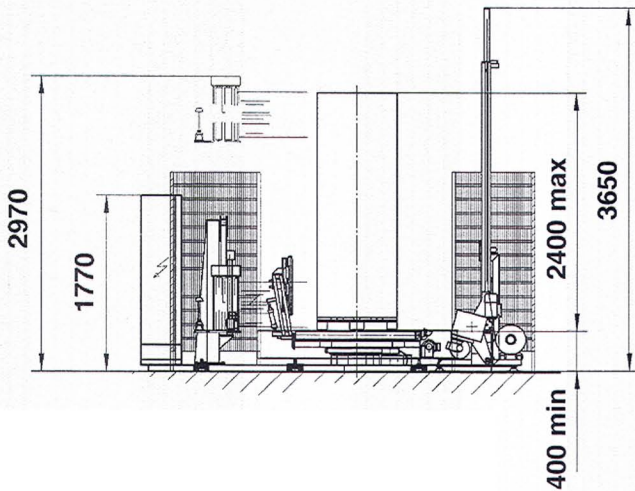
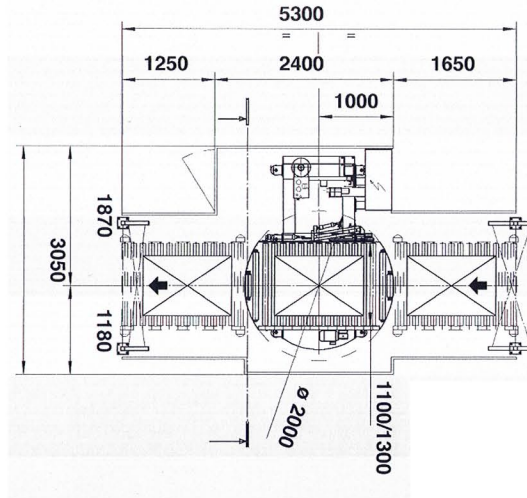
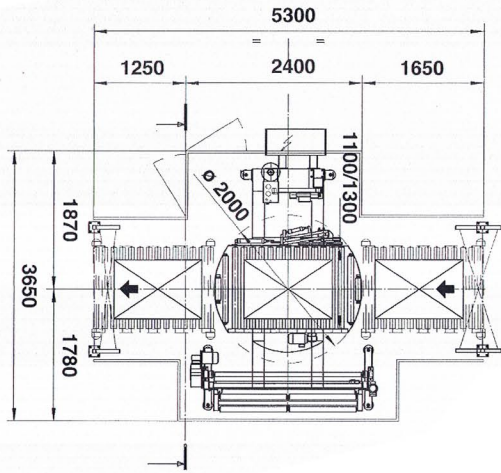

- Power supply 240/480V + 60HZ
- Pneumatic supply 90 PSI
- Maximum pallet size 51.1" x 43.3" (footprint) and 86.6" tall
- Minimum pallet size 23.6" x 31.5" (footprint) and 19.7" tall

## Corporate Headquarters

Gateway Centre Blvd. | Pinellas Park, FL 33782

Tel: 727.578.5000 | Fax: 727.578.1300

[www.polypack.com](http://www.polypack.com) | Email: [info@polypack.com](mailto:info@polypack.com)



**poly** innovation  
**pack** in packaging  
equipment