

HANDLE PACK 600 SERIES



The Handle Pack 600 series tape handle applicators are specifically designed to apply high tensile strength carry handles onto carton multipacks. The 600 series uses a rotary head tape delivery system that applies the tape strip around and underneath the multipack for improved safety and support.

The carry handle is applied in the transverse direction (at 90 degrees in reference to the infeed).

These compact machines offer easy access to the tape supply and machine components, which facilitates easy tape handle reloading and machine maintenance operations.

The Handle Pack 600 series machines are built in stainless steel with transparent polycarbonate safety doors.

The Handle Pack 600 series utilize a patented system that offers reliable, simple operation in addition to the added customer conveniences of the carry handle pack.

Machine Dimensions:

Length: 1600mm

Width: 1500mm

Height: Conveyor height + 750mm

Speed: 25 cycles/minute

Electrical: 3x400V + Ground

Power: 1.25Kw

Tape Handle Specifications:

Length: 630mm

Width: 25mm

Spool Length: 6500 meters

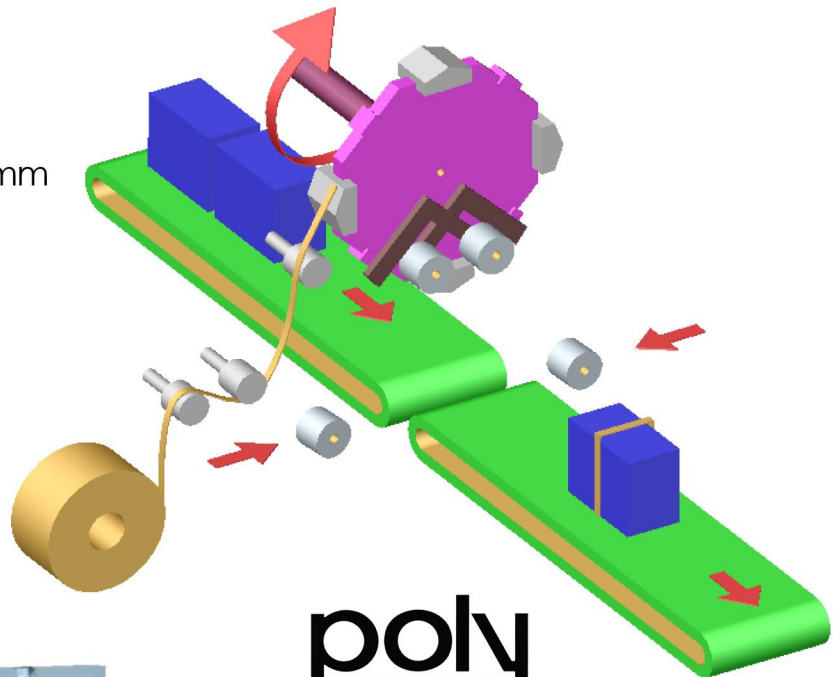

**poly
pack** inc.

www.POLYPACK.com

727.578.5000

info@polypack.com

3301 Gateway Centre Blvd.

Pinellas Park, FL USA

HANDLE PACK 600 SERIES

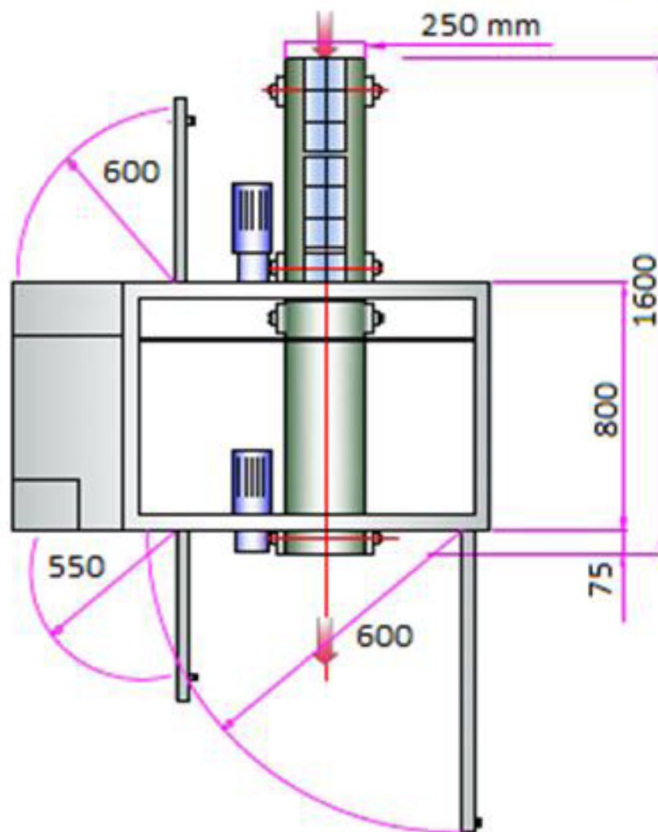
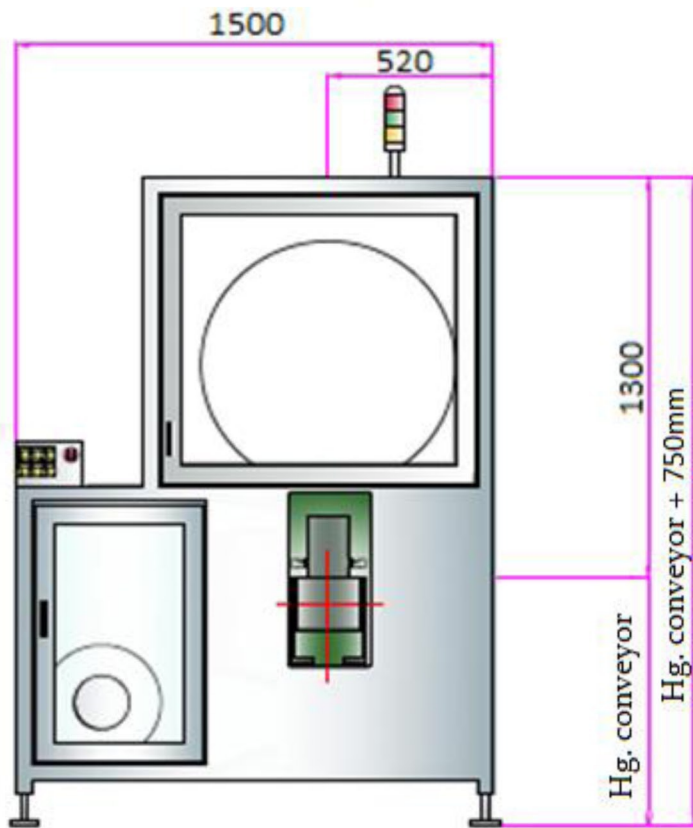

**poly
pack** inc.

www.POLYPACK.com
727.578.5000
info@polypack.com
3301 Gateway Centre Blvd.
Pinellas Park, FL USA